

General Information:

- Read instructions carefully before beginning assembly.
- Identify each component from material list.
- Do not use excessive force when assembling components.
- To clean this product, for best results use a soap solution and high-pressure water.
- In the event of missing or defective parts, please call our customer service department at 1-866-363-8834.

Materials List:

Part #	Description	Quantity
1	Decorative Address Sign (Nantucket or Winchester)	1

Hardware Pack Includes:

2	#8 x 3" steel screw	4
3	Nylon washer	12
4	Plastic snap cap (4 each - white, tan, & grey)	12
5	Two 4x4 wood posts - not included (48" length recommended)	

Tools Required:

- Cordless drill
- Robertson drill bit
- Tape measure
- Level
- Shovel



Nantucket



Winchester

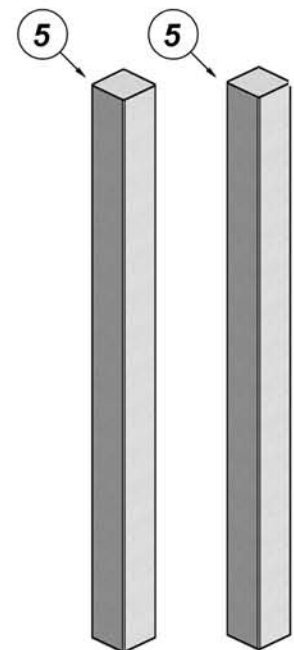
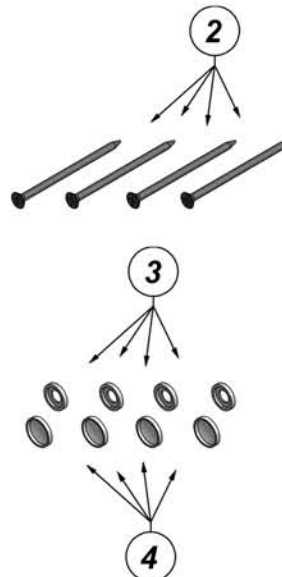
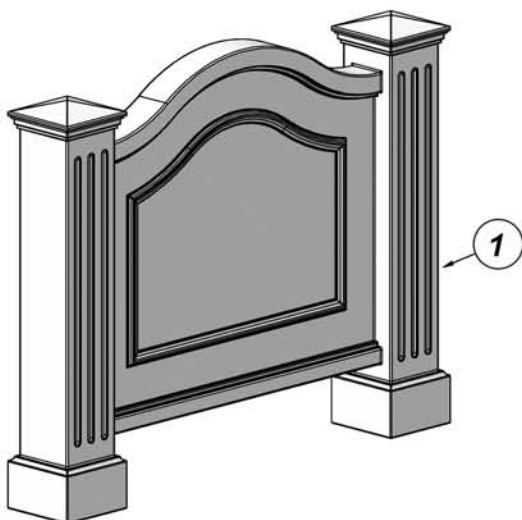

IMPORTANT NOTE:

- 4x4 wood posts, pre-mix concrete, and address plaques are NOT included with Mayne address signs

Assembly Instructions

MIS005

1.

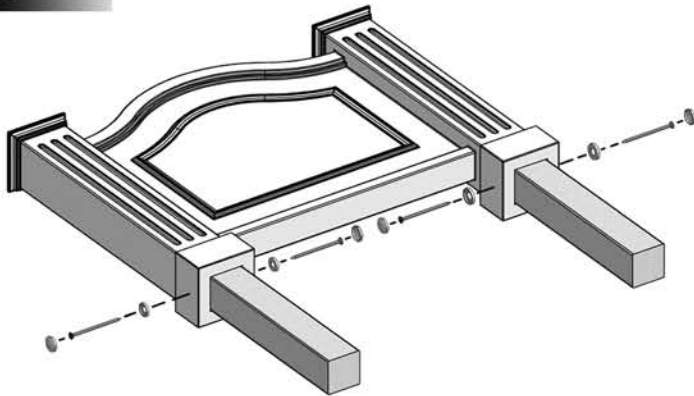

Insert a 4x4 wood post (part 5, not included) into one of the holes in the sign. Leave about 20 inches sticking out of the bottom. Hold the post steady and secure it to the base with a 3 inch screw (part 2) through each side as illustrated. Do not over tighten the screws, it could cause the plastic to dimple or crack. Repeat this step for the second wood post. Please note that nylon washers (part 3) and plastic snap caps (part 4) are provided to cover the screw heads.

2.

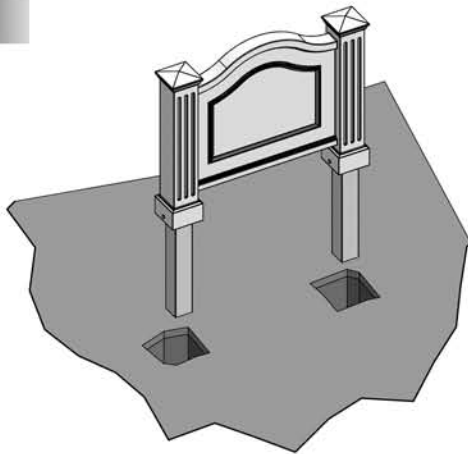

Set the address sign in the desired location and mark the position of the wood posts. Dig a 20" deep hole for each post.

3.

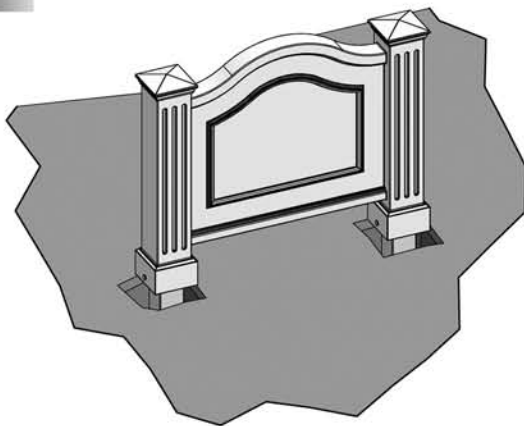

Place the sign into the holes, and adjust the depth if needed. Use a level to check the signs orientation. Once you are satisfied, fill in the holes. For added stability in high wind or traffic areas, we recommend using pre-mix concrete (not included).

Questions?

If you have any questions concerning the assembly or installation of this product and require assistance, please call our Customer Service Department at 1-866-363-8834, Weekdays from 8:00am to 4:00pm Eastern standard time. If you have any comments or suggestions about our product or service, please let us know! Call: **1-866-363-8834**, or Email: info@mayneposts.com

MAYNE[®]
Mail Posts of Distinction
www.mayneposts.com